

PATENT SPECIFICATION

Application Date: Aug. 29, 1921. No. 22,899/21.

189,518

Complete Accepted: Nov. 29, 1922.

COMPLETE SPECIFICATION.

Improvements in or relating to Logarithmic Calculating Devices.

I, GASTON BEAUVAIS, of 98, Avenue de Versailles, Paris, France, a citizen of the French Republic, do hereby declare the nature of this invention and in what manner the same is to be performed, to be particularly described and ascertained in and by the following statement:—

Ordinary slide rules have rectilinear scales graduated in such a manner that the distance from the origin to all the points of the graduation are proportional to the logarithms of numbers.

The accuracy of the reading being a function of the clearness of the graduation, the longer the scale the easier will be the reading of the result. But, on the other hand, the length of the scale is limited by conditions of lightness, size, ease of transport and of manipulation.

It has been proposed, with a view to obtaining logarithmic calculators of great scale length and capable of being easily handled, to trace the scale on curves the radii vectors of which relatively to a determined pole increase according to the law $r = a\theta + m$, a and m being positive parameters, the graduation being such that the angles at the centre formed by the divisions, the pole and the origin of the graduation, are proportional to the logarithms of numbers.

In these calculators, the determination of a number is obtained in the same way as the determination, in polar coordinates, of the corresponding point of the scale, that is to say that this determination consists in measuring an angle and a radius vector.

Any logarithmic calculator of the kind indicated comprises therefore a totaliser for the angles and a totaliser for radii vectors, involving respectively algebraic summations of angles and vectors.

The present invention relates to a logarithmic calculator of this kind and is characterised in that the totalising device for the radii vectors is devised in such a manner that, as soon as the result-

ing radius vector becomes greater than that of the extreme point of the graduation, it is automatically diminished by the difference between the radii vectors of the extreme point and of the point which is the origin of the graduation.

The calculator forming the subject-matter of this invention allows therefore a result of any order of magnitude to be obtained, without transfer, without intermediate readings and without accessory calculations, which is not realised in any logarithmic calculator with a folded scale known up to this day.

The accompanying drawings illustrate, by way of example several forms of carrying out this invention.

Fig. 1 is a plan view of a logarithmic calculator.

Fig. 2 is an elevation of the alidade with an adding device.

Fig. 3 is a corresponding plan view thereof.

Fig. 4 shows a calculator provided with a second type of adding device.

Fig. 5 is a plan view of a second type of adding device.

Fig. 6 is a corresponding sectional elevation.

Fig. 7 shows a modification of the calculator.

Fig. 8 illustrates, on an enlarged scale, the rider of the alidade.

Fig. 9 is a section of the rider.

Fig. 10 illustrates a modification of the calculator.

Fig. 11 shows a totalising plate corresponding to this modification.

Fig. 12 is a corresponding alidade.

The various forms of carrying out the invention which are illustrated may differ from one another by the equation of the curve or curves on which is traced the logarithmic scale.

In a first form of arrangement of the scale, the said scale is constituted by a series of concentric semi-circles, bearing the graduation. For convenience of the

[Price 1/-.]

Price 4s 6d.

description, we shall successively examine the working for the various operations.

MULTIPLICATION—

The graduation is such that the angles at the centre are proportional to the logarithms of numbers.

If α_p is the angle corresponding to the logarithm of the number p ,

& if α_q is the angle corresponding to the logarithm of the number q ,

$\alpha_p + \alpha_q$ will be the angle corresponding to the product $p q$ according to the properties of the logarithms.

The first semi-circle bears a graduation from 0 to π ; the second from π to 2π , etc. . . Therefore a semi-circle of degree or order x bears a graduation from $(x-1)\pi$ to πx .

It will be supposed that the graduation corresponding to the number p is on the semi-circle of degree or order x , α'_p being the angle formed by the radius vector which passes through the number p and the radius passing through the point of origin of the graduation on the semi-circle of degree or order x .

In the same way, it will be supposed that the graduation corresponding to the number q is on the semi-circle of degree or order y , α'_q being the angle formed by the radius vector which passes through the number q and the radius passing through the point of origin of the graduation on the semi-circle of degree or order y .

We have therefore:

$$\begin{aligned}\alpha_p &= (x-1)\pi + \alpha'_p \\ \alpha_q &= (y-1)\pi + \alpha'_q \\ \alpha_p + \alpha_q &= (x+y-2)\pi + \alpha'_p + \alpha'_q.\end{aligned}$$

In the case where $\alpha'_p + \alpha'_q < \pi$, the degree of the line bearing the figure of the product $p q$ is therefore:

$$x + y - 1$$

and in case where $\pi < \alpha'_p + \alpha'_q < 2\pi$

we may write

$$\alpha'_p + \alpha'_q = \pi + \beta.$$

therefore:

$$\begin{aligned}\alpha_p + \alpha_q &= (x+y-2)\pi + \pi + \beta \\ &= (x+y-1)\pi + \beta.\end{aligned}$$

and consequently the product $p q$ is on the line of degree $x+y$.

Supposing the lines of the scale are numbered from 0 a line of degree x will have for number $(x-1)$, a line of degree y will have for number $(y-1)$, etc. . .

Consequently, the degree of the result $p q$ being $(x+y-1)$ or $(x+y)$, the number of the line would be $(x+y-2)$ or $(x+y-1)$, that is to say $(x-1) + (y-1)$ or $(x-1) + (y-1) + 1$.

By generalising, it will be seen that for

the convenient reading of the results it is necessary to have:

1° - A totalising apparatus giving the sum:

$$\alpha'_p + \alpha'_q + \dots + \alpha'_x - n\pi \leq \pi.$$

2° - A totalising apparatus indicating the number of the line of the scale, i.e.:

$$(x-1) + (y-1) + \dots + n.$$

DIVISION:

The angle corresponding to a quotient $\frac{p}{q}$ will be, referring to the preceding theory:

$$\alpha_p - \alpha_q = (x-y)\pi + \alpha'_p - \alpha'_q.$$

In this case $\alpha'_p - \alpha'_q$ is compulsorily smaller than π .

In the case where

$$\alpha'_p - \alpha'_q \geq 0$$

there is obtained:

$$\alpha_p - \alpha_q \geq (x-y)\pi$$

and consequently the number of the line on which is the result is

$$x - y.$$

In the case where

$$-\pi < \alpha'_p - \alpha'_q < 0$$

there is obtained:

$$(x-y-1)\pi < \alpha_p - \alpha_q < (x-y)\pi$$

and therefore the number of the line on which is the result is

$$x - y - 1.$$

In other words, the equation:

$$\alpha_p - \alpha_q = (x-y)\pi + \alpha'_p - \alpha'_q \quad \text{with} \quad \alpha'_p < \alpha'_q$$

might have been written.

$$\alpha_p - \alpha_q = (x-y-1)\pi + (\pi + \alpha'_p) - \alpha'_q \quad \text{with} \quad (\pi + \alpha'_p) > \alpha'_q.$$

It will be seen that in this case the totalising apparatus for the angles must give:

either

$$\alpha'_p - \alpha'_q$$

or

$$\pi + \alpha'_p - \alpha'_q$$

and the totaliser for the lines:

either

$$x - y$$

or

$$x - y - 1.$$

In the present form of carrying out the invention, the scale a (Figure 1) is constituted by a series of 10 concentric semi-circles, having o as a centre. The difference of two consecutive radii is constant. This scale is graduated in such a manner that the angles at the centre determined by the origin radius $o p$ and the divisions are proportional to the

logarithms of numbers; the digits marked opposite each division correspond to numbers. For instance, if the scale is graduated from 1 to 10, the digit 1 will be at the origin of the graduations, 10 at the end, as shown in Figure 1. Obviously, the graduations of the 10 lines are made in the same direction.

The totalising apparatus of the angles is constituted in the following manner:

A plate *b*, of smaller radius than that of the smallest circle, is loosely mounted on an axis passing through the centre *o* of the scale and at right angles to its plane. An alidade *c* is also loosely mounted on this axis and has two branches. One of these branches sweeps over the entire scale and is provided with a handle *d*; the other, of smaller length than the radius of the plate *b*, is provided with a handle *e*; this branch is flexible and can come in contact at its end with the plate *b*; the surface of contact is lined with a plastic material of high friction coefficient, so that the plate may be drawn along without sliding. The branch provided with the handle *d* carries a transparent plate on which is marked a reference radius *r*. The plate *b* bears two diametrically opposite reference lines *f* adapted to come into alinement with similar reference lines *g* on the frame.

In addition the plate *b* carries two diametrically opposite teeth *m* which gear with the teeth of a second plate *n* loose on an axis *a* parallel to the axis *o*. This plate is provided with 10 teeth to each of which corresponds a division of a graduation from 0 to 9. At the origin, the division 0 is opposite a reference point *t* of the frame, and the teeth *m* are arranged for engaging with the teeth of the plate *n* only after a rotation of π .

The totaliser for the lines is constituted by an endless ribbon *k* (Figures 2 and 3) mounted on the alidade *c* by means of two rolls on which the ribbon is wound; it can be moved with the finger. It bears such graduations that the space between two divisions is equal to the difference between the radii of two consecutive curves of the scale. The numerals 0 to 9 are repeated to denote the graduations of the ribbon. At the origin, the graduations must coincide with the corresponding lines of the scale, the first of these lines serving as an index, having opposite to it the graduation 0.

By means of the devices described multiplication and division can be effected in the following manner:

MULTIPLICATION:

Before the operation, all the reference lines coincide the reference line *r* coin-

cing with the origin *o p*. By means of the handle *d*, the reference line *r* is caused to pass to the graduation corresponding to the number *P*; during this movement, the plate *b* has not moved. Then, by means of the handle *e*, the reference line *r* is caused to coincide with *o p*; during this movement, the plate *b* rotates, in the direction of the arrow *i* through an angle α'_p .

The same operation is executed for the number *Q* and the following. The plate *b* has then rotated through an angle equal to $\alpha'_p + \alpha'_q + \dots + \alpha'_x$.

At this moment, by means of the handle *e*, the reference line *r* coinciding with the radius *o p*, after the last operation, the plate *b* is returned to its original position, within a margin of 180° , by rotating in the direction of the arrow *i*, that is to say two reference points *f* and *g* are caused to coincide. Consequently, the reference point *r* makes with the origin *o p* an angle of

$$(\alpha'_p + \alpha'_q + \dots + \alpha'_x) - n\pi < \pi$$

which had to be obtained.

This reference line *r* gives therefore the first place or location on which is situated the division of the product sought for. In order to find the line constituting the second place or location, use is made of the second totalising apparatus, called the line totaliser.

When the reference line *r* is brought on the division *P*, as previously stated, the ribbon *k* is manipulated by means of the finger so as to cause the division of the ribbon which was on the first line of the scale (*i.e.* division 0) to come on the line of degree *x* on which the number *P* is situated.

When the reference line *r* is brought on the division *Q*, the ribbon is again manipulated so as to cause the division which was on the line 1 of the scale to come on the line *y* on which the number *Q* is situated. Opposite the graduation 0 of the ribbon is therefore situated the number line

$$(x - 1) + (y - 1) = x + y - 2.$$

The logarithms of numbers the quotient of which is a power of 10 differ only by their characteristics, the mantissa remaining identical. Now, the mantissa suffices to characterise a number, the characteristic determining only the number of digits of the whole part. Consequently, when the number $(x + y - 2)$ is greater than 10, it may be replaced without inconvenience by the number $x + y - 2 - 10u < 10$; the number which will then be found on the scale must be multiplied by $10u$.

Moreover, a slide rule has simply to give the successive digits forming the number, the whole part being determined by different considerations. This operation is automatically carried out by the ribbon, the graduations of which are continuous. It will therefore be seen that the ribbon indicates the value:

$$x + y - 2 - 10u < 10.$$

10 u being an integer.

For a rotation of the plate b greater than π the plate n rotates through a division, and the digit 1 comes opposite the reference point, indicating the number to be added to the indications given by the ribbon for obtaining the number of the line on which the result is. For a rotation of $2\pi, 3\pi, 4\pi, \dots$ the reading is taken opposite the reference point 2, 3, 4, ... numbers to be added to the number $x + y - 2 - 10u$ previously obtained, that is to say the number of the graduation of the ribbon which is to serve as a reference line instead of the zero graduation.

It will therefore be seen that the number thus obtained, by generalising:

$$(x - 1) + (y - 1) + \dots + (z - 1) + n$$

30 n being the number of rotations of π radians of the plate b , corresponds to the number of the line containing the result. In practice, the units digit only is taken, as above stated. For this reason, when $n = 10a$, a being any whole number, it is not necessary to add it to the indication $(x - 1) + (y - 1) + \dots + (z - 1)$; this operation is automatically carried out, the division 0 of the plate n coming opposite the reference point t for a rotation of $10a\pi$ of the plate b .

DIVISION:

Supposing the quotient $\frac{P}{Q}$ is to be found.

45 In accordance with the theory explained above, the operations to be effected are the following:

1° - By means of the handle d , bring the reference line r opposite the number P .

50 2° - By means of the handle e , bring back r to its initial position. The plate b rotates in the direction of the arrow i through the angle α'_p .

55 3° - By means of the handle e , bring the reference line r opposite the number Q . The plate b rotates in the reverse direction to the arrow i through the angle α'_q .

60 Supposing $\alpha'_p > \alpha'_q$, the plate b will have rotated in the direction of the arrow i through an angle

$$\alpha'_p - \alpha'_q.$$

And if $\alpha'_p < \alpha'_q$, the plate b will rotate in reverse direction to the arrow i through an angle

$$\alpha'_q - \alpha'_p \tag{65}$$

which is equal to a rotation of the plate b in the direction of the arrow i through an angle:

$$\pi + \alpha'_p - \alpha'_q.$$

70 4° - Bring back, by means of the handle d , the reference line r to its initial position.

75 5° - By means of the handle e , move the plate so that its reference points f and g may coincide. The reference line r makes with the origin $o p$ an angle of

$$\alpha'_p - \alpha'_q \text{ or } \pi + \alpha'_p - \alpha'_q.$$

80 6° - At the time the operation described above in paragraph 1° is performed, the ribbon k is acted upon so as to bring the graduation 0 opposite the line of degree or order x on which the number p is. Opposite the initial line of the scale is then situated the division $(x - 1)$ of the ribbon.

85 7° - At the time the operation indicated above in paragraph 3° is performed, the graduation of the ribbon k which is opposite the line of degree or order y where the number q is, is brought opposite the initial line of the scale. At this time the zero of the graduation of the ribbon is opposite the number line

$$(x - 1) - (y - 1) = x - y.$$

90 If $\alpha'_p > \alpha'_q$, the plate b has turned in the direction of the arrow i through an angle smaller than π . Therefore, the wheel n has not moved and opposite the reference line t is the digit 0.

95 If $\alpha'_p < \alpha'_q$, the plate b has turned in the reverse direction to the arrow i through an angle smaller than π . Therefore, the wheel n has rotated to the extent of one tooth in the reverse direction to the arrow i and, consequently, opposite the reference line t is the digit 9.

100 In this case, it would be advisable to add 9 to the result $x - y$, which obviously comes to the same as subtracting 1 from $x - y$, since the scale is divided proportionally to common logarithms.

105 Consequently, it will be seen that the second locus is on the line opposite the graduation 0 of the ribbon, or opposite the graduation preceding the 0, that is to say opposite the graduation 9. Opposite the reference line t is read off the number of the graduation (0 or 9) which must be used.

120 After using the apparatus, all the parts are brought back to the original positions.

(a) the reference line r to the line $o p$ (abutments z ensure this automatically).

(b) the zero of the ribbon *h* opposite the first line of the scale numbered 0.

(c) the zero of the wheel *n* and the reference line *t* coincide.

5 (d) the reference points *f* and *g* are caused to coincide, by rotating the plate *b* in the direction of the arrow *i*.

A second form of the line totalising apparatus (Figs. 4, 5 and 6) automatically giving the number of the line where the result is to be found, is constructed as follows:—

10 The wheel *n* of the previous example is covered by another wheel *n*¹ loosely mounted on the pin *s* of the wheel *n*. The wheel *n*¹ has ten holes through which the divisions of the wheel *n* may be seen. As previously stated, the wheel *n* has teeth in mesh with the teeth *m* of the disc *b* (Figure 1). Figure 4 shows in dotted lines the generating circles of the gear thus formed. A plate *h* (Figures 5 and 6) secured to the base plate of the apparatus separates the wheel *n* from the wheel *n*¹, the said plate having holes corresponding to those of the wheel *n*¹ so that the divisions of the wheel *n* may be seen. Moreover, divisions from 0 to 9 are marked on the said plate *h* around the wheel *n*¹, the said divisions corresponding to those of the wheel *n*, but arranged in the opposite direction. A reference line *t*¹ is marked opposite one of the holes of the wheel *n*¹. At the outset the division mark 0 of the plate *h*, the division mark 0 of the wheel *n* and the reference line *t*¹ coincide. As already stated, the lines of the scale are numbered from 0 to 9, the number of the first line being 0 and that of the last line being 9, the number of a line of degree *x* being (*x*—1).

20 (Figure 1). Figure 4 shows in dotted lines the generating circles of the gear thus formed. A plate *h* (Figures 5 and 6) secured to the base plate of the apparatus separates the wheel *n* from the wheel *n*¹, the said plate having holes corresponding to those of the wheel *n*¹ so that the divisions of the wheel *n* may be seen. Moreover, divisions from 0 to 9 are marked on the said plate *h* around the wheel *n*¹, the said divisions corresponding to those of the wheel *n*, but arranged in the opposite direction. A reference line *t*¹ is marked opposite one of the holes of the wheel *n*¹. At the outset the division mark 0 of the plate *h*, the division mark 0 of the wheel *n* and the reference line *t*¹ coincide. As already stated, the lines of the scale are numbered from 0 to 9, the number of the first line being 0 and that of the last line being 9, the number of a line of degree *x* being (*x*—1).

25 The above-described totalising device works as follows:

MULTIPLICATION:

45 Let P and Q be two numbers to be multiplied together. The steps to be taken for totalising the angles are the same as in the example previously described. The following steps are taken to totalise the lines:

50 1. If the number P is on the line of degree *x*, that is to say the number line (*x*—1), place a finger on the wheel *n*¹ opposite the division (*x*—1) of the plate *h*. The said finger is then moved to a position opposite the division 0 of the plate *h* by rotating the wheel *n*¹ in a direction opposite to that of the arrow *i*¹ (Figures 4 and 5). At that moment the reference line *t*¹ of the wheel *n*¹ lies opposite the division mark (*x*—1) of the wheel *n*.

55 2. If the number Q is on the line of degree *y*, that is to say the number line

(*y*—1), the steps just described are taken, so that the reference line *t*¹ of the wheel *n*¹ is opposite the division (*x*—1) + (*y*—1) of the wheel *n*. If the angle corresponding to the arc comprised between two successive divisions of the wheel *n* or of the plate *h* (that is to say $\frac{2\pi}{10}$) is indicated by γ , it will be seen that in the course of the first operation the wheel *n*¹ has been rotated (relatively to the wheel *n* and in opposite direction to the arrow *i*¹) through an angle equal to (*x*—1) γ . In the second case the wheel *n*¹ has been rotated through (*y*—1) γ . Therefore its total rotation is $\{(x-1)+(y-1)\gamma$, which proves that the reference line *t*¹ is really opposite the division (*x*—1) + (*y*—1) of the wheel *n*, assuming that (*x*—1) + (*y*—1) is not greater than 9 and that the wheel *n* has remained stationary.

70 If now (*x*—1) + (*y*—1) is greater than 9, the reference line *t*¹ is opposite the division (*x*—1) + (*y*—1) — 10 of the wheel *n* if the latter has remained stationary. Thus assuming that a number of factors are to be multiplied together, this device gives the division

$$(x-1) + (y-1) + \dots - 10u < 10$$

75 like the device previously described always provided the wheel *n* has remained stationary.

80 Now according to a preceding statement, the wheel *n* has rotated through one-tenth of a revolution, that is to say through the angle γ in the direction of the arrow *i*¹ whilst the disc rotated through π . If the disc has rotated through more than *n* π and less than (*n*+1) π , the wheel *n* will have been rotated through *n* γ in the direction of the arrow *i*¹. Everything has therefore proceeded as if the wheel *n*¹ had rotated (relatively to the wheel *n* and in opposite direction to the arrow *i*¹) through an angle

$$\{(x-1) + (y-1) + \dots + n\}\gamma,$$

85 that is to say the line of reference *t*¹ is now opposite the division

$$(x-1) + (y-1) + \dots + n - 10u < 10$$

90 of the wheel *n*.

DIVISION:

95 The operations 1°, 2°, 3°, 4° and 5° previously described remain the same. It is to be noted again that, during these operations if $a'_p > a'_q$, the plate *b* turns in the direction of the arrow *i* through an angle smaller than π and, consequently, the wheel *n* does not move.

100 If on the contrary $a'_p < a'_q$, the plate *b* turns in the reverse direction to the arrow

65

70

75

80

85

90

95

100

105

110

115

120

i through an angle smaller than π and causes the wheel n to turn in the reverse direction to i^1 , through a tenth of a revolution.

5 The wheel n is then operated in the following manner:

(a) Place the finger on the wheel n^1 and bring the reference line t^1 opposite the graduation of n corresponding to the number of the line x (operation effected at the same time as 1°).

10 (b) Place the finger on the wheel n^1 opposite the 0 of the graduation of the frame and, by rotating in the direction to the arrow i^1 , bring the finger opposite the division of the frame corresponding to the number of the line y . A rotation of y divisions will have been effected (operation made after 3°).

20 Consequently, the wheel n^1 has rotated in the opposite direction to the arrow i^1 through $(x-1)\gamma$, the number of the line of degree x being $(x-1)$ and γ being the angle comprised between two successive divisions; and then through $(y-1)\gamma$ in the direction of the arrow i^1 . The said wheel n^1 has therefore rotated in the opposite direction to i^1 through a total amount of $(x-y)\gamma$ relatively to the wheel

30 n if the latter has remained stationary, that is to say if $a'_p > a'_q$. If on the contrary $a'_p < a'_q$, the wheel n rotates in the opposite direction to i^1 through an angle equal to $\frac{2\pi}{10}$, that is to say equal to γ .

35 Consequently, everything happens as if the wheel n^1 had rotated through $(x-y-1)\gamma$ relatively to the wheel n and in opposite direction to the arrow i^1 , that is to say the reference line t^1 is opposite the division $x-y-1$ of the wheel n , this being the result aimed at.

In place of rotating the wheel n^1 through an angle $(y-1)\gamma$ in the direction of the arrow i^1 as in the operation described under (b), the said wheel n^1

45 could be rotated in the opposite direction to the arrow i^1 through an angle equal to $2\pi - (y-1)\gamma$. Thus, the wheel n^1 would have rotated through an angle

$$50 \quad (x-y)\gamma + 2\pi$$

in the opposite direction to i^1 if the wheel n had remained stationary, and through an angle $(x-y-1)\gamma + 2\pi$ if the wheel n had been rotated through the angle γ in opposite direction to i^1 , as previously, stated.

Any risk of error is eliminated when proceeding as described above, since the wheel n would always be operated in the same direction. In order to facilitate this operation, the alidade c is provided with two sets of divisions, one of which indicates the number of the lines and the

60

other indicating the difference between this number and 10. The operation (b) is therefore carried out by placing the finger on the wheel n^1 opposite the divisions of the plate h corresponding to the number $(y-1)$ of the line, and by bringing the finger opposite 0 of the divisions of the plate h . In the course of this operation the wheel has consequently rotated through $\{10 - (y-1)\}\gamma$, that is to say through $2\pi - (y-1)\gamma$.

The calculator provided with the second form of line totaliser may be used by constructing it in the following manner, for making additions and subtractions.

The wheel n is provided with a projection q located under one of its teeth and engaging the teeth of a wheel n^3 the said teeth being 10 in number. The wheel n^3 is keyed to a pin s^1 which also carries another 10-tooth wheel n^2 , a projection q^1 of the wheel n^1 engaging the teeth of the said wheel n^2 (Figure 6). The wheel n^2 is provided with divisions from 0 to 9. According to this arrangement, when the wheel n is rotated through 2π , the wheel n^3 and consequently the wheel n^2 are rotated through $\frac{2\pi}{10}$.

On the other hand, and quite independently from this movement, a movement of rotation of the wheel n^1 through 2π causes the wheel n^2 to rotate through $\frac{2\pi}{10}$. At the outset the reference line t^1 of the wheel n^1 coincides with the zero of the wheel n and with that of the divisions of the plate h . Furthermore, the 0 of the wheel n^2 coincides with a reference line t^2 marked on the said plate h .

On the same plane as the scale a is arranged a particular circular scale p, p^1 , which is divided for instance into 10,000 equal parts, so that the angles at the centre formed by the divisions, the centre of the scale and the origin are proportional to the numbers from 1 to 10,000.

In the following description, and for the sake of simplicity, the number represented by the first four figures of a number, starting from the right, is termed "units". Thus, the scale $p-p^1$ indicates units, that is to say figures up to 9999, or the number formed by the four first figures (starting from the right) of a number greater than 9999.

The wheel n^1 serves to register the tens of thousands of the numbers.

The wheel n serves to register the tens of thousands arising from the additions of lower units.

The wheel n^2 indicates hundreds of thousands. At the origin, a reference point t^2 of the frame is opposite the zero 1 of n^2 .

The operation is as follows:

ADDITION:

Two numbers are to be added, for instance 56,390 and 78,620; it is first necessary to register them.

1° - Registration of the number 56,390.

(a) tens of thousands (5).

Place the finger on the wheel n^1 opposite the graduation 5 of the frame; then, by rotating in the reverse direction to the arrow v , bring the finger opposite the zero of the frame.

The wheel n has remained stationary; the wheel n^1 has turned relatively to the wheel n through five-tenths of a revolution in the reverse direction to the arrow v^1 that is to say in the direction of the graduation of n ; the reference line t^1 indicates therefore 5 on the wheel n .

(b) units: (6390).

By means of the handle d cause the reference point r to pass over the graduation of $p p^1$, indicating the number of units. The plate b remains stationary.

By means of the handle e , bring back the reference point to its initial position, the plate b rotates through a corresponding angle in the direction of the arrow i .

2° - Registration of the number 78,620.

(a) tens of thousands (7).

Place the finger on the wheel n^1 opposite the graduation 7 of the frame; then, by rotating in the reverse direction to the arrow v^1 , bring the finger opposite the zero of the frame.

The wheel n has not moved; the wheel n^1 has turned through seven-tenths of a revolution in the reverse direction to the arrow v^1 . Consequently, the wheel n^1 has turned, since the beginning of the operation, through twelve-tenths of a revolution and the reference line t^1 is opposite the graduation 2 of the wheel n . As the rotation of n^1 has been greater than 2π the claw of the wheel n^1 has caused the wheel n^2 to turn through one-tenth of a revolution. Therefore, at this moment the reference point t^2 indicates 1 on the wheel n^2 of the hundreds of thousands and the reference point t^1 indicates the digit 2 of the tens of thousands wheel.

(b) units: (8.620).

The same operations as in the first case are effected; the total rotation of the plate b in the direction of the arrow i is therefore:

$$\frac{6390}{10000} \pi + \frac{8620}{10000} \pi = \frac{15.010}{10.000} \pi$$

As the rotation of the plate b has been greater than π the wheel n turns in the direction of the arrow v^1 through one-tenth of a revolution; opposite the reference line t^1 of the wheel n^1 appears therefore the digit 3.

By bringing back opposite each other by turning in the reverse direction to the arrow i the reference points $f g$ of the plate b and by acting on the handle e , the reference line r indicates on the scale $p p^1$ the number 5010.

The total is therefore 135010.

It will be seen from the above that an exact number of tens of thousands is recorded merely by operating the wheel n^1 . When this number of tens of thousands exceeds 9, the wheel n^1 must rotate the wheel n^2 through a division, this being obtained by means of the projection q^1 and the teeth of n^2 . On the other hand, the wheel n^1 remains stationary when units (numbers smaller than 10000) only are recorded. The wheel n however rotates through one-tenth of a revolution when the total amount of units recorded exceeds 10000.

The wheel n^2 must rotate through one division when the wheel n has completed one revolution; this is obtained by means of the projection q and the wheel n^3 , keyed to the pin s^1 of the wheel n^2 . Thus owing to this double movement of rotation the wheel n^2 indicates the hundreds of thousands from the recording of tens of thousands or from the recording of units.

SUBTRACTION:

The registration of the first number is effected as for addition, *viz*: the number 135.010. The second number for instance 78620, is registered in the following manner:

Place the finger on the wheel n^1 opposite the graduation 7 on the wheel n^1 and bring it back, by turning in the reverse direction to v^1 opposite the graduation 0 of this wheel. In addition, the claw of n^1 has come into engagement with a tooth of n^2 , and the reference point then indicates 0 instead of 1 on this wheel.

2° Units.

By means of the handle e , bring the reference point r on the number 8620. The plate b rotates in reverse direction to the arrow i through an angle greater than that through which it had been previously turned for the registration of the number 135.011. Consequently, the wheel n rotates in a reverse direction to v^1 , and the reference point t^1 then indicates the number 5.

By means of the handle d , bring back the reference line r to its initial position. Then, by means of the handle e , the reference points f and g are caused to coincide, by causing the plate to rotate in the reverse direction to the arrow i . The reference line r then indicates the number 6390 on the scale $p p^1$.

The result is therefore 56390.

It will be seen that it is possible to make several successive additions and subtractions without reading results other than the final result, provided the latter is included between 0 and 1,000,000. A suitable graduation of the wheel n^2 combined with suitable teeth would allow an increase of this limit; it would be sufficient to increase the number of the teeth.

10 SQUARE ROOTS, SINES, TANGENTS.

Each division obviously is provided with the number it represents. It is also possible to mark opposite each division in different type or in different colour, the square of the number, the angle the trigonometric tangent of which is measured by the number, and the angle the sine of which is measured by the number. Thus four different scales are obtained on the same division.

COMMON LOGARITHMS.

The scale is graduated in such a manner that the angles at the centre formed by the origin and the divisions are proportional to the common logarithms of the numbers from 1 to 10. We know that the knowledge of the mantissa is sufficient.

The logarithms of the numbers from 1 to 10 vary from 0 to 1; the scale has a total angle of 10π . Therefore, a variation of logarithms of 0, 1 corresponds to an angle variation of π .

Consequently, the first digit of the mantissa is given by the numeral of the line on which is situated the number for which the logarithm is to be found.

The other digits are obtained by causing the reference line to pass through this division and by effecting the reading on the scale p^1 . The latter measures, in fact, the fraction of π determined by the angle at the centre formed by the origin and the division corresponding to the number; it measures in consequence the fraction to be added to the first digit obtained.

It is obvious that the scale may have any number of lines. Instead of semi-circles, thirds or quarters of a circle may be used and generally speaking any arcs of the form $\frac{2\pi}{p}$, p being a whole number. In this case the number of teeth m of the disc b is of course equal to p and the number of teeth l of the wheel n is equal to the number of lines of the scale. The wheel n is then provided with divisions of as many figures from 0 as there are lines on the scale.

In a modification, (Figure 7) the concentric circles of the apparatus may be replaced by an Archimedes' spiral of 10

convolutions. The circular arcs may be replaced by the same number of spiral arcs. The divisions are marked on these spiral arcs as on the circular arcs, that is to say so as to correspond to angles, at the centre, proportional to the logarithms of numbers.

Consequently if a_p is the angle at the centre corresponding to a number p , a_q the angle at the centre corresponding to the number q , the angle a_{pq} corresponding to the product $p q$ will be:

$$a_{pq} = a_p + a_q$$

and the angle at the centre corresponding to the quotient $\frac{p}{q}$

$$a_{\frac{p}{q}} = a_p - a_q$$

If $r = a\theta + m$ is the equation of the spiral, the radius vector r_p corresponding to the number p is

$$r_p = a a_p + m$$

the radius vector r_q of the number q :

$$r_q = a a_q + m$$

the radius vector r_{pq} of the product $p q$:

$$\begin{aligned} r_{pq} &= a a_{pq} + m \\ &= a a_p + a a_q + m \\ &= r_p + r_q - m \end{aligned}$$

and the radius vector of $r \frac{p}{q}$ of the quotient $\frac{p}{q}$:

$$\begin{aligned} r \frac{p}{q} &= a a_{\frac{p}{q}} + m \\ &= a a_p - a a_q + m \\ &= r_p - r_q + m \end{aligned}$$

In this form of construction, the angle totaliser is constituted in the same manner as in the previous ones, by a drum b^1 , which operates in an absolutely similar manner.

The line totaliser (Figures 7, 8 & 9) is constituted by a simple wire k^1 provided with reference points r^2 the spacing apart of which is equal to the radius vector of the number 10. This wire winds on two rolls having vertical axes. A rider c^1 sliding on the alidade c^2 draws along this wire in the direction of the arrow 6 if the lever l^1 is acted upon and in the reverse direction if the lever l^2 is acted upon. Before each movement, the arrow f^1 of the rider is placed against the 1 of the scale. The lever l^1 is acted upon for the numbers comprised by the numerator of the expression to be calculated. The algebraic sum of the displacements of the wire is equal to the radius vector of the expression to be calculated and one of the reference points is always

exactly on the line where the result is to be read.

The device therefore does away with any reading other than that of the final result.

On the other hand, the key of the lever l^2 is perforated and the spindle of a crank m^1 which engages in the opening is operated at the same time as this lever; this crank carries a shoe p^2 which renders the alidade c^2 integral with the plate b^1 when the lever l^2 is operated upon. It is therefore possible to combine in a single movement the movements of the wire and of the plate b^1 , so that for introducing a number in an operation, it suffices to point at this number with the arrow f^1 of the rider.

Finally, the disc b^1 is provided (like the disc b of the constructions illustrated in Figures 1 and 4) with references f and g , but there is only one reference f and one reference g in place of two of each as in the said Figures 1 and 4.

The operation is as follows:

MULTIPLICATION:

Supposing the numbers p and q are to be multiplied. At the beginning of the operation, the reference lines f and g coincide, the arrow f^1 of the slider is placed at the origin of the graduation and one of the reference lines r^2 is on the initial line of the scale.

1° By acting on the lever l^1 , the arrow f^1 is brought in coincidence with the number p .

The plate b^1 does not move during this movement; the radius vector of the reference line r^2 is r_p .

2° By acting on the lever l^2 , the alidade is brought back against its abutment.

In this movement, the plate b^1 turns through the angle $\alpha'_p = \alpha_p - 2n\pi$, ($\alpha'_p < 2\pi$) in the direction of the arrow i .

3° The slider c^1 is brought back against its abutment without acting on any lever.

4° By acting on the lever l^1 , the arrow f^1 is brought into coincidence with the number q .

The plate b^1 does not move during this movement and the radius vector of the reference line r^2 becomes:

$$r_p + r_q - m$$

5° By acting on the lever l^2 , bring back the alidade against its abutment.

In this movement, the plate b turns through the angle $\alpha'_q = \alpha_q - 2n\pi$ ($\alpha'_q < 2\pi$) in the direction of the arrow i . The plate b has therefore turned through the total angle: $\alpha'_p + \alpha'_q$.

6° Without acting on any lever, bring the arrow f^1 into coincidence with the reference line r^2 .

7° By acting on the lever l^2 , bring the reference lines f and g in coincidence.

The result is read at the point of the arrow f^1 .

DIVISION:

Supposing the numbers p and q are to be divided

1° By acting on the lever l^1 , bring the arrow f^1 into coincidence with the number p .

2° By acting on the lever l^2 , bring the alidade against its abutment.

3° Without acting on any lever, bring back the slider c^1 against its abutment.

4° By acting on the lever l^2 , bring the arrow into coincidence with the number q .

The radius-vector of the reference line r^2 becomes therefore:

$$r_p - r_q + m$$

In addition, the plate b turns in the reverse direction to the arrow i through the angle α'_q . The plate has therefore turned in all through the angle:

$$\alpha'_p - \alpha'_q$$

5° By acting on the lever l^1 , bring back the alidade against its abutment.

6° Without acting on any lever, bring the arrow f^1 into coincidence with the reference line r^2 .

7° By acting on the lever l^2 bring the reference lines f and g into coincidence.

The result is read at the point of the arrow f^1 .

Instead of tracing the scale on a single arc of an Archimedes' spiral as shown in Figure 7, the said scale could be traced without any inconvenience on a series of several arcs as shown in Figure 10.

In the said example, the scale comprises 10 arcs having respectively for their equation:

1st arc: $r = a\theta + m$, θ varying from 0 to π .

2nd arc: $r = a\theta + m + a\pi$, θ varying from 0 to π .

10th arc: $r = a\theta + m + 9a\pi$, θ varying from 0 to π .

In the more general case in which the scale would comprise n arcs, the equations of the said n arcs would be respectively:

1st arc: $r = a\theta + m$, θ varying from 0 to ω .

2nd arc: $r = a\theta + m + a\omega$, θ varying from 0 to ω .

n th arc: $r = a\theta + m + (n-1)a\omega$, θ varying from 0 to ω .

where ω is an angle chosen so that the ratio $\frac{2\pi}{\omega}$ is a whole number.

The construction in Figure 10 comprises like the preceding ones a totaliser of angles and a totaliser of lines.

The totaliser of angles is constituted by two transparent circular discs b^2 b^3 loosely mounted on a spindle at right angles to the table and passing through the pole of the spiral arcs.

Each of the said discs has a datum or reference line drawn along a diameter and consequently passing through the pole.

In the general case in which the scale comprises n arcs, the discs b^2 and b^3 would each have $\frac{2\pi}{\omega}$ reference radii forming between them an angle ω .

By means of suitably arranged shoes or pincers it is possible to drive: either (1) the disc b^2 alone or, (2) the two discs simultaneously.

It will be seen that the said device is similar to those comprising two alidades utilised in certain existing logarithmic calculators; it works in the same way which will be described later on.

The totaliser of lines is constituted by the combination of the two discs b^2 and b^3 with two other transparent circular discs c^2 and c^3 rotating about the same spindle, each having two datum or reference lines symmetrical relatively to the pole, each of the said lines being an arc of an Archimedes' spiral of the equation $r=10a\theta+m$, θ varying from 0 to π in the example under the consideration.

The radius-vector of the end of the datum or reference arc is therefore $r=10a\pi+m$. That of the end of the graduation or division is $r=a\pi+m+9a\pi=10a\pi+m$.

Consequently the end of a spiral of c^2 or c^3 and of the spiral of the scale can coincide. The same applies to the origins or beginnings of the spirals since the radius-vector of the origin is always $r=m$.

In the general case of the number of spirals is $\frac{2\pi}{\omega}$ and the equation of each of them is $r=na\theta+m$, θ varying from 0 to ω and the tangents at points of the same radius vector of two consecutive spirals forming between them an angle equal to ω .

It is possible to move either (1) the disc c^2 alone or (2) the two discs c^2 and c^3 simultaneously.

In combination with the discs b^2 and b^3 , it is possible;

Either (1) to move the four discs together or, (2) drive the discs b^2 , c^2 and c^3 , or (3) drive only the discs b^2 and c^2 .

Before carrying out an operation (multiplication or division) the reference lines of b^2 and of b^3 and the origin of the division are made to coincide, the origin and the end of one of the spirals of each of the discs c^2 and c^3 coinciding with the

origin and the end of the division or graduation.

To make the explanation clearer, it will be assumed in the following that in every algebraic sum of angles, the result will always be an angle greater than 0 and smaller than π .

MULTIPLICATION OF A NUMBER N BY A NUMBER Q.

The operations are as follows:—

(1) Act on the four discs simultaneously until the reference lines of b^2 and b^3 pass through the division of the scale, corresponding to the number N. The four discs will then have been turned to an angle α_n , in the direction of the graduation or division, which will be called positive direction. Moreover, the number of reference radii of the discs b^2 and b^3 is in this case $\frac{2\pi}{\omega} = \frac{2\pi}{2\pi} = 1$.

(2) Leaving b^3 stationary, move the three other discs until one of the spirals of c^3 intersects the reference line of b^3 on the number N. It is obvious that it was necessary to turn in the negative direction.

We had for radius-vector of N on the scale

$$r_n = a\alpha_n + m + (t-1)a\pi,$$

t being the number indicating the particular convolution on which the number N is situated.

Since c^3 passes through the point of the division or graduation which corresponds to the number N, the radius-vector of c^3 at that point is also r_n .

This vector r_n corresponds relatively to c^3 , to an angle θ_n with the origin; consequently the spiral c^3 has turned relatively to b^3 to an angle θ_n in the negative direction. But we had:

$r_n = a\alpha_n + m + (t-1)a\pi = 10a\theta_n + m$ and consequently

$$\theta_n = \frac{\alpha_n + (t-1)\pi}{10}$$

(3) Leaving b^3 and c^3 stationary, bring b^2 and c^2 to the starting point. A stop could be arranged so as to avoid any risk of error.

(4) By operating the four discs, bring b^2 to pass through the division Q. The four discs will have been turned to α_q in the positive direction. Consequently the disc b^3 will have been turned to an angle $\alpha_n + \alpha_q$ in the positive direction.

(5) Leaving b^3 stationary, move the three other discs until one of the spirals of c^2 passes through the division Q.

From the same reasoning as in the previous case, it will be seen that the spiral c^2 and consequently the spiral c^3 have turned relatively to b^3 —if s is the number indicating the particular con-

volution on which the number Q is situated—to an angle $\frac{\alpha_q + (s-1)\pi}{10} = \theta_q$ (in the negative direction) that is to say that the spiral c^3 has turned in all to the extent of $\theta_n + \theta_q$ in the negative direction relatively to b^3 .

But $\theta_n + \theta_q = \frac{\alpha_n + \alpha_q + \{(t-1) + (s-1)\}\pi}{10}$

Now the vector R of the spiral c^3 corresponding to the angle $\theta_n + \theta_q$ is:

$R = 10a(\theta_n + \theta_q) + m.$

Therefore

$R = (t-1)a\pi + a\alpha_n + (s-1)a\pi + a\alpha_q + m$
 $R = r_n + r_q - m$

r_q being the radius-vector corresponding to the division Q of the scale. Consequently $R = r_{nq}$, where r_{nq} is the radius-vector of the number indicating on the scale the product NQ.

It follows from the preceding:

(1) That the reference line b^3 having been turned to the angle $\alpha_n + \alpha_q$ has totalised the angles; consequently the product NQ is on the said reference line.

(2) That the spiral c^3 is intersected by the reference line b^3 at a point of the radius-vector equal to r_{nq} ; consequently the result NQ must be at that point, and it is sufficient to read the graduation of the scale corresponding to the point in question.

Division $\frac{N}{Q}$ The first two operations remain the same as in the multiplication.

(3) Leaving b^3 and c^3 stationary, one spiral of c^2 is brought to pass through the division of the scale corresponding to the number Q.

(4) Leaving b^3 stationary, b^2 is brought to pass through the number Q.

In this movement, rotation is in the positive direction to an angle $\theta_q = \frac{\alpha_q + (s-1)\pi}{10}$ corresponding to the angle

which the radius-vector of c^2 , passing through Q, forms with the vector of origin which coincides with the reference line of b^2 .

Consequently c^3 has turned to an angle $\theta_n - \theta_q$ equal to $\frac{\alpha_n + (t-1)\pi}{10} - \frac{\alpha_q + (s-1)\pi}{10}$

in the negative direction and relatively to b^3 . This angle could be driven

$\theta_n - \theta_q = \frac{\alpha_n - \alpha_q + \{(t-1) - (s-1)\}\pi}{10}$

The radius-vector R^1 corresponding to it is:

$R^1 = 10a(\theta_n - \theta_q) + m$
 $= (t-1)a\pi + a\alpha_n + m - \{(s-1)a\pi + a\alpha_q\}$
 $= r_n - r_q + m.$

$R^1 = r \frac{n}{q}$, where $r \frac{n}{q}$ is the radius-vector of the number indicating on the scale the number $\frac{N}{Q}$.

Consequently the radius-vector of the intersection of b^3 and of c^3 is equal to the radius-vector of the division corresponding to the result $\frac{N}{Q}$.

(5) By acting on the four discs, the disc b^2 is brought to its initial position. Consequently b^3 has been finally turned through the angle $\alpha_n - \alpha_q$ corresponding to the angle $\frac{n}{q}$ of the division $\frac{N}{Q}$. The result will be therefore read at the intersection of b^3 and c^3 .

In the preceding for the purpose of rendering the description clearer, no attention has been paid to the fact that the following cases may occur:—

- (1) $\alpha_n + \alpha_q > \pi.$
- (2) $\alpha_n - \alpha_q < 0.$
- (3) $\theta_n + \theta_q > \pi.$
- (4) $\theta_n - \theta_q < 0.$

In each of these cases, the reference line considered comes outside the scale; but there is on each disc a reference line which passes through the scale. The whole takes place as if the reference line considered had automatically moved to the extent of π in the positive direction or in the negative direction. Consequently it is sufficient to utilise the reference lines passing through the scale, neglecting those which are outside.

If in the general case we make $\omega = 2\pi$ we shall obtain for the scale a series of n arcs of the equation:

1st arc: $r = a\theta + m$, θ varying from 0 to 2π .
 2nd arc: $r = a\theta + m + 2a\pi$ or $r = a(\theta + 2\pi) + m, \dots$
 nth arc: $r = a\theta + m + 2(n-1)a\pi$ or $r = a\{\theta + 2(n-1)\pi\} + m,$

that is to say the said scale is a single arc of a spiral of the equation $r = a\theta + m$, θ varying from 0 to $2n\pi$.

In this case the reference spirals on each disc c^2, c^3 are to the number of $\frac{2\pi}{\omega} = \frac{2\pi}{2\pi} = 1$ and this spiral has for its equation $r = na\theta$, θ varying from 0 to 2π .

Nevertheless the described construction relating to Figure 10 makes it possible to arrange a second scale in the half-circle not occupied by the first. This second scale drawn in chain dotted lines in Figure 10, can be used for instance for operations on the trigonometric lines.

Having now particularly described and ascertained the nature of my said invention and in what manner the same is

to be performed, I declare that what I claim is:—

1. A logarithmic calculator in which the scale is drawn on the arcs of curves made according to the equation $r = a\theta + m$, characterised by the totaliser or device summing up the radii-vectors being such that the resultant vector is automatically decreased or increased, as soon as it becomes greater than the radius-vector of the end of the scale or smaller than that of the origin, by a quantity equal to the difference between the said two vectors.

2. A logarithmic calculator according to Claim 1, characterised by the fact that the parameter (for example a) being zero, the scale is drawn on arcs of circles, the difference between the radii of two consecutive arcs being constant.

3. A logarithmic calculator according to Claims 1 and 2, characterised by the angle adding device being constituted by a disc with reference marks which can turn about an axis passing through the centre of the arcs, the said disc being capable of being secured to an alidade which turns about the same axis.

4. A logarithmic calculator according to Claims 1—3, characterised by a device counting the revolutions of the angle adding device, greater than π , constituted by a graduated disc rotating relatively to a fixed reference mark and provided with teeth which enable it to be periodically driven by the angle adding device or totaliser provided for the purpose with two opposite teeth.

5. A logarithmic calculator according to Claims 1—4, characterised by the device for adding radii-vectors being constituted by an endless band mounted by means of two rollers on the alidade and carrying a graduation or division which corresponds to the number and to the distance of the arcs of the scale, the indications of the said band being corrected by those of the counting device which records the number of revolutions greater than π of the angle adding device or totaliser.

6. A logarithmic calculator according to Claims 1—4, characterised by the fact that the part of the said calculator constituted by the totaliser for angles, together with the device counting its revolutions of π and a circular scale divided into equal arcs, forms an adding and subtracting machine.

7. A logarithmic calculator according to Claims 1—4, characterised by the device for adding the lines or line totaliser, being constituted by the combination of the

device counting the π revolutions of the angle totaliser with a perforated disc mounted on the same spindle and provided with a reference mark drawn opposite one of the holes.

8. A logarithmic calculator according to Claim 1, in which the scale is drawn on 'an Archimedes' spiral, characterised by the device for adding the vectors being constituted by an endless thread or wire mounted on the alidade by means of two vertical rolls and carrying two reference marks dividing the wire into two equal portions.

9. A logarithmic calculator according to Claims 1 and 8, characterised in that the endless thread is moved by means of a pointer or runner on which a two-armed lever is pivoted for the purpose of gripping either run of the thread between the corresponding arm of the lever and the runner to move the said thread in either direction.

10. A logarithmic calculator according to Claims 1, 8 and 9, characterised by one of the handles of the traveller operating a crank carrying a shoe which couples the angle totaliser disc and the alidade.

11. A logarithmic calculator according to Claim 1, characterised by the scale being drawn on a series of n arcs of an Archimedes' spiral of the equation $r = a\theta + m + (n - 1) a\omega$, where ω is an angle chosen between zero and 2π so that the ratio $\frac{2\pi}{\omega}$ is a whole number and θ varies from zero to ω .

12. A logarithmic calculator according to Claims 1 and 11, characterised by the device for adding the angles being constituted by two identical discs rotatable about an axis passing through the pole of the scale and carrying reference radii forming between them an angle ω .

13. A logarithmic calculator according to Claims 1, 11 and 12, characterised by the device for adding the vectors, being constituted by two identical discs rotatable about an axis passing through the pole of the scale and carrying reference curves which are arcs of a logarithmic spiral having for their equation $r = na\theta + m$, θ varying from zero to ω , in which the tangents at points of the same radius vector of two consecutive arcs form between them an angle equal to ω .

Dated this 29th day of August, 1921.

G. BEAUVAIS,

Per pro., Boulton, Wade & Tennant,
111 & 112, Hatton Garden, London,
E.C. 1,
London Agents.

Fig. 1

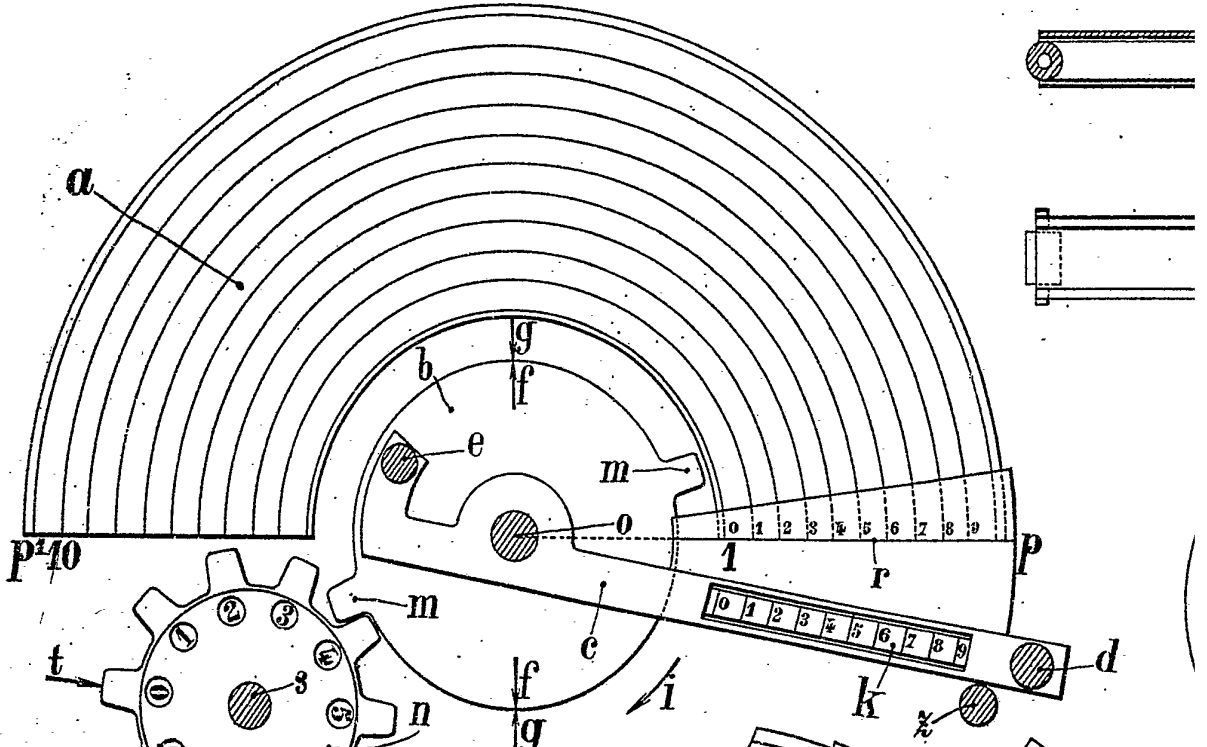
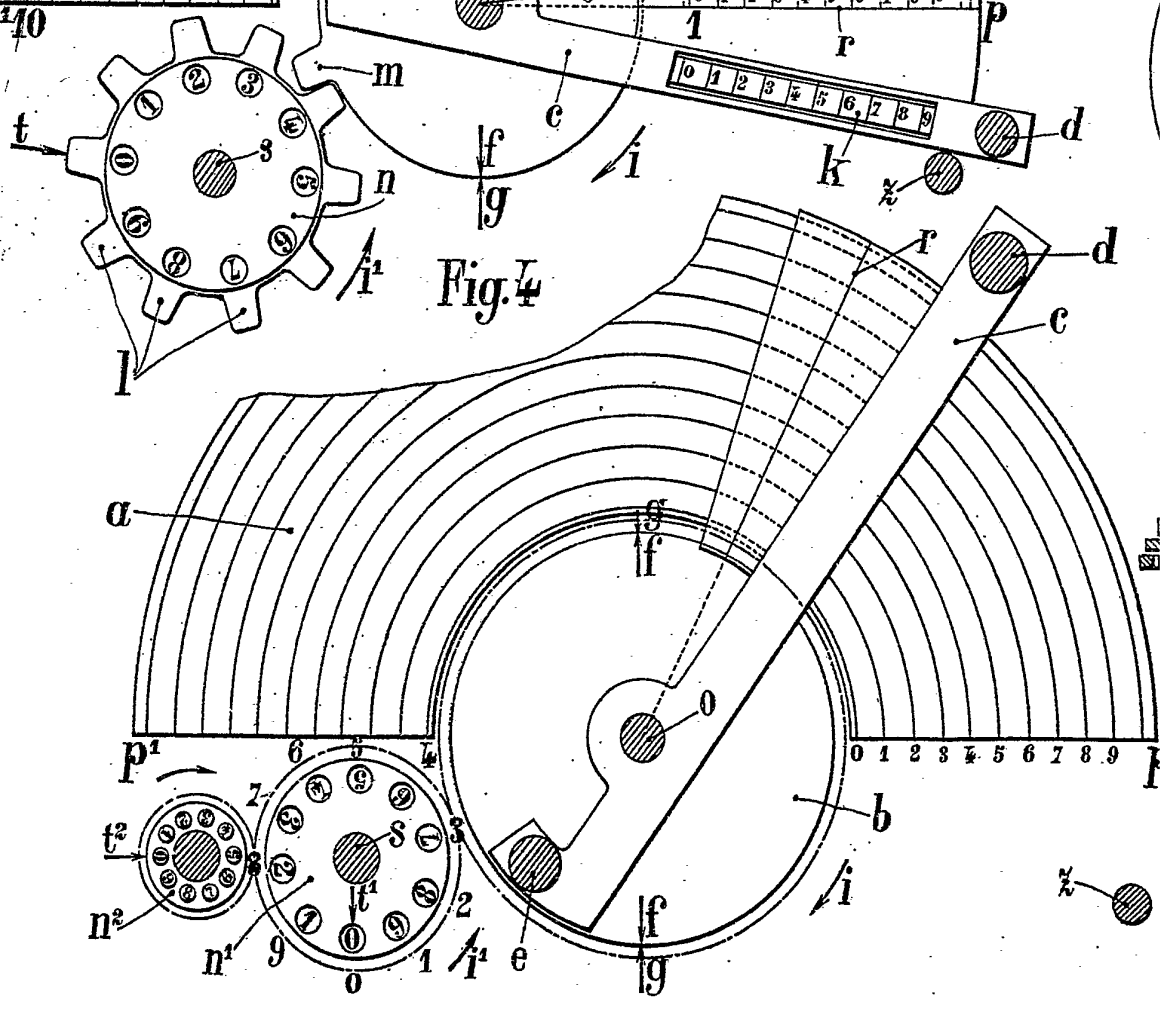

Fig. 4



[This Drawing is a reproduction of the Original on a reduced scale.]

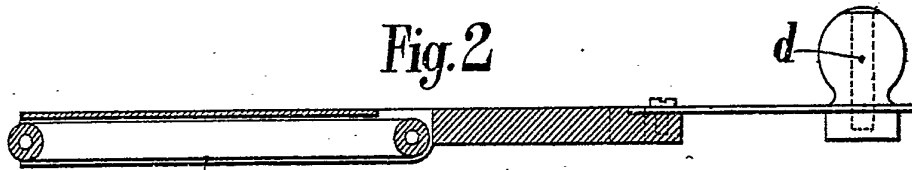

Fig. 2

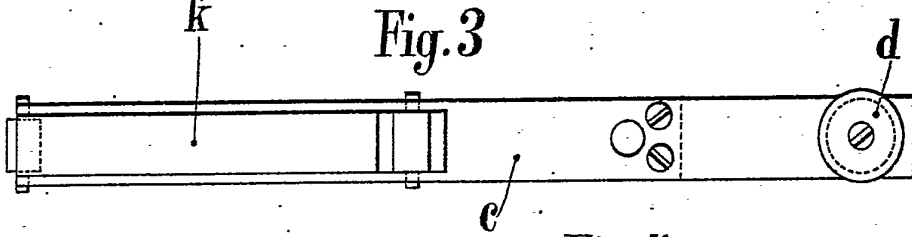

Fig. 3

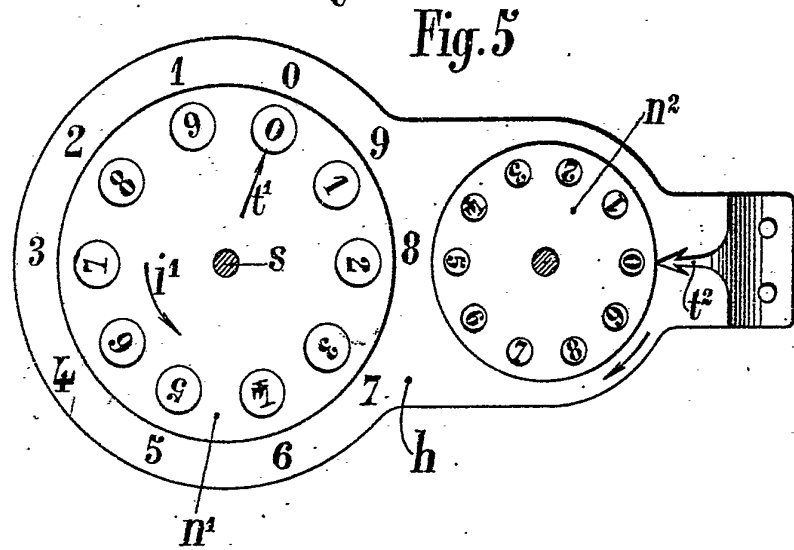
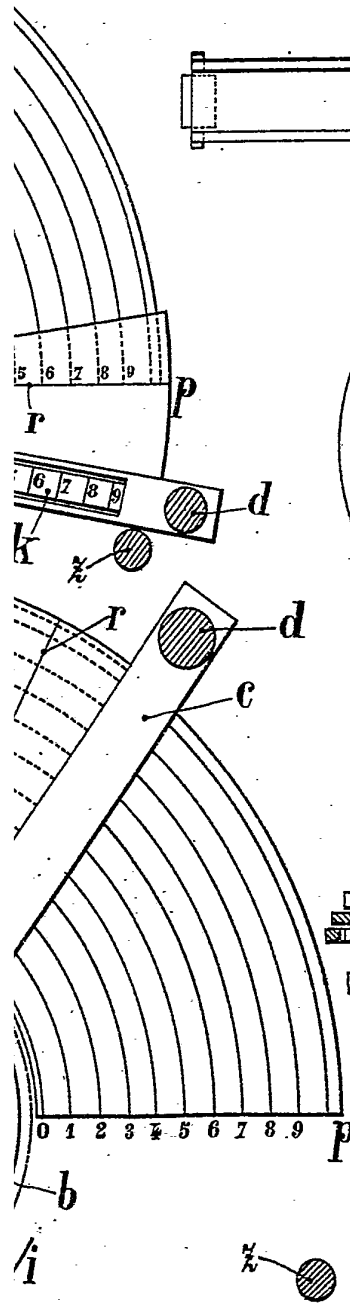

Fig. 5

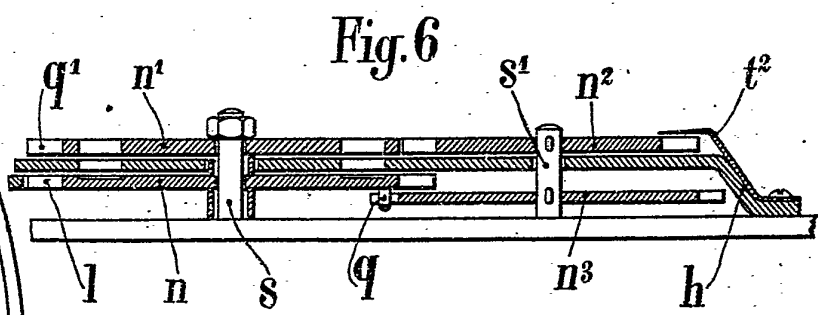

Fig. 6

Fig. 1

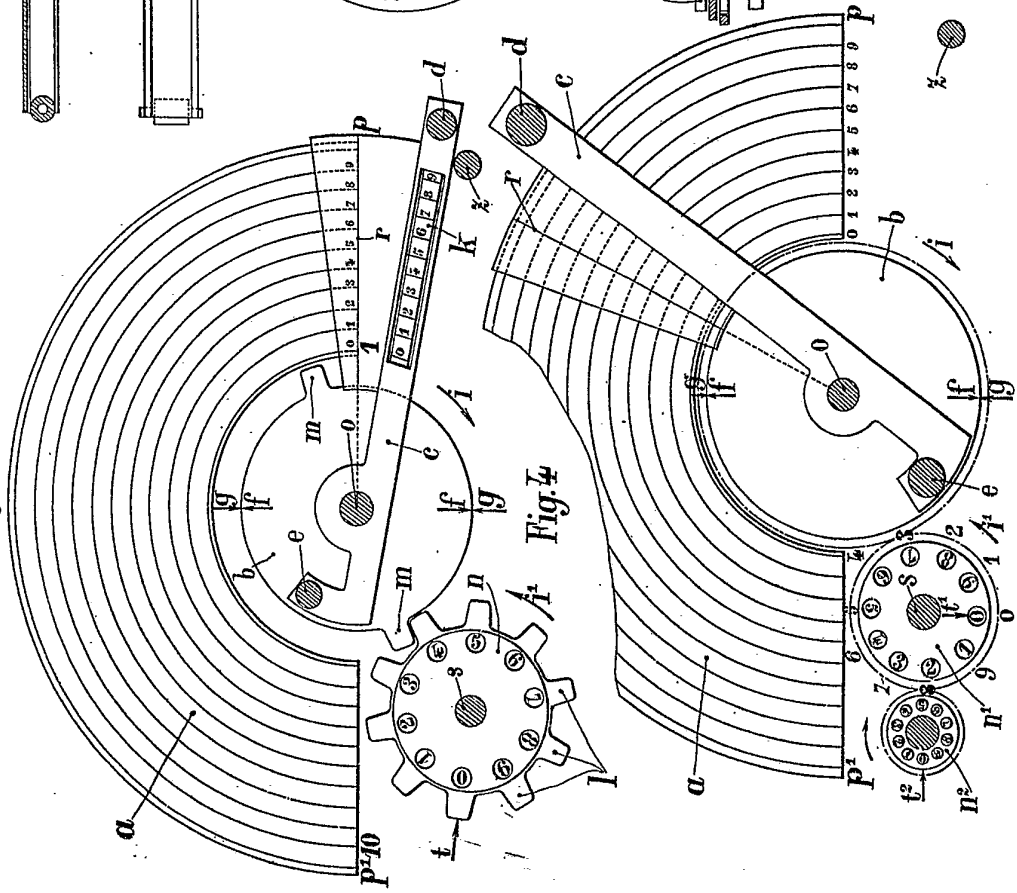

Fig. 4

Fig. 5

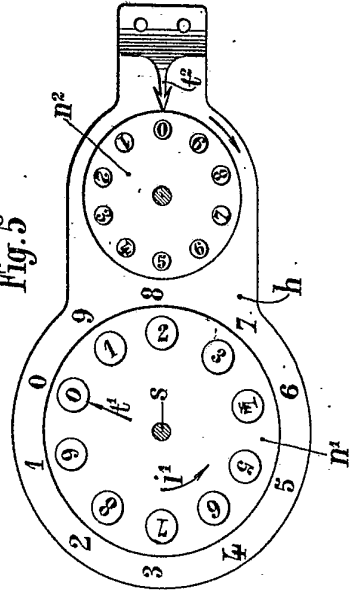

Fig. 2

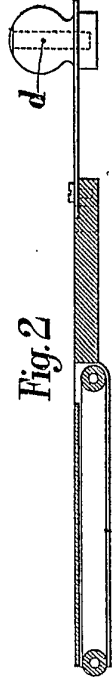

Fig. 3

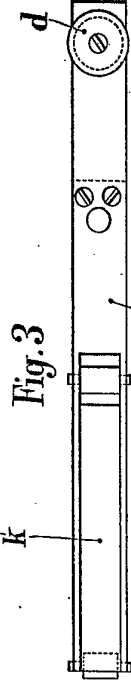
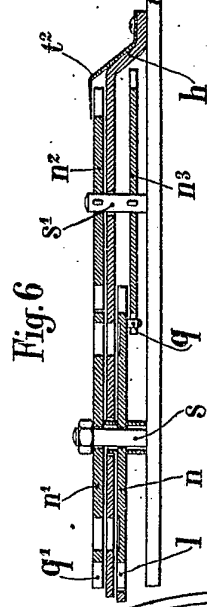

Fig. 6



[This Drawing is a reproduction of the Original on a reduced scale.]

[This Drawing is a reproduction of the Original on a reduced scale.]

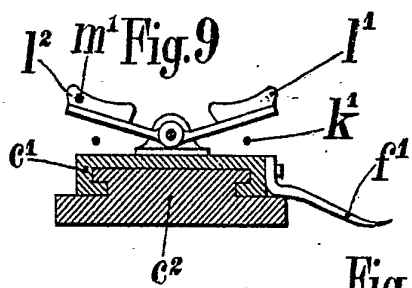
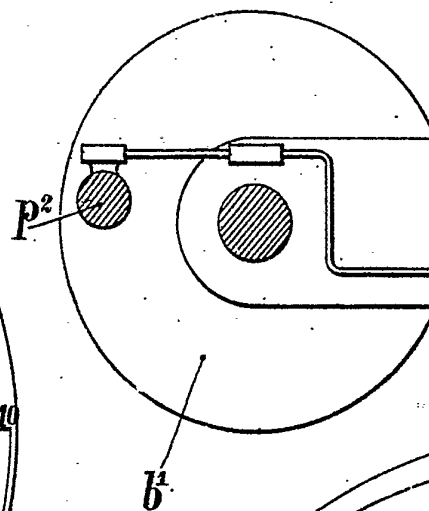
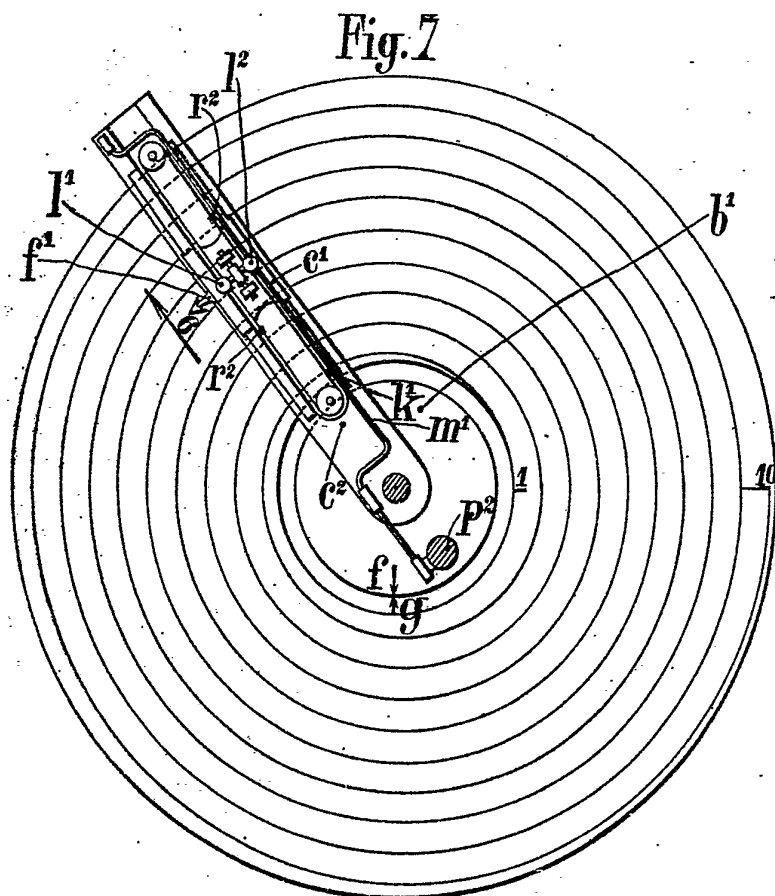

Fig. 12

Fig. 11

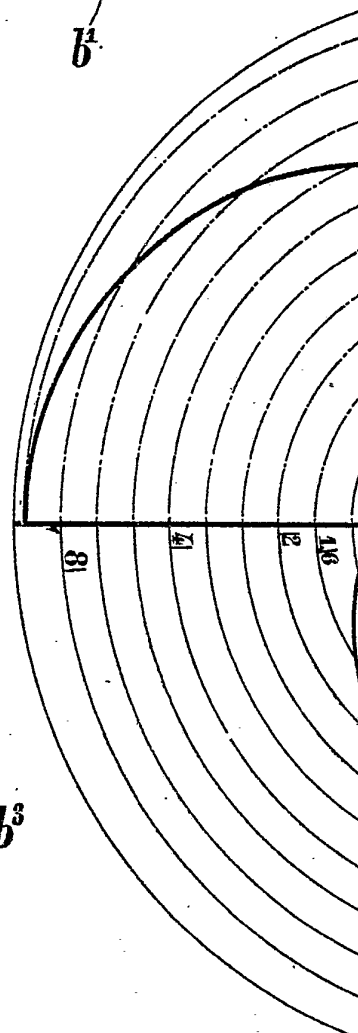
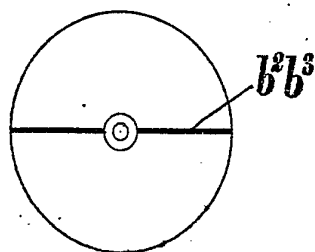
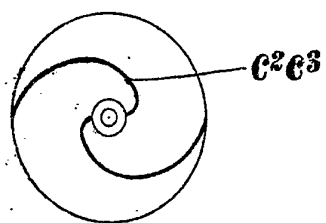

Fig. 8

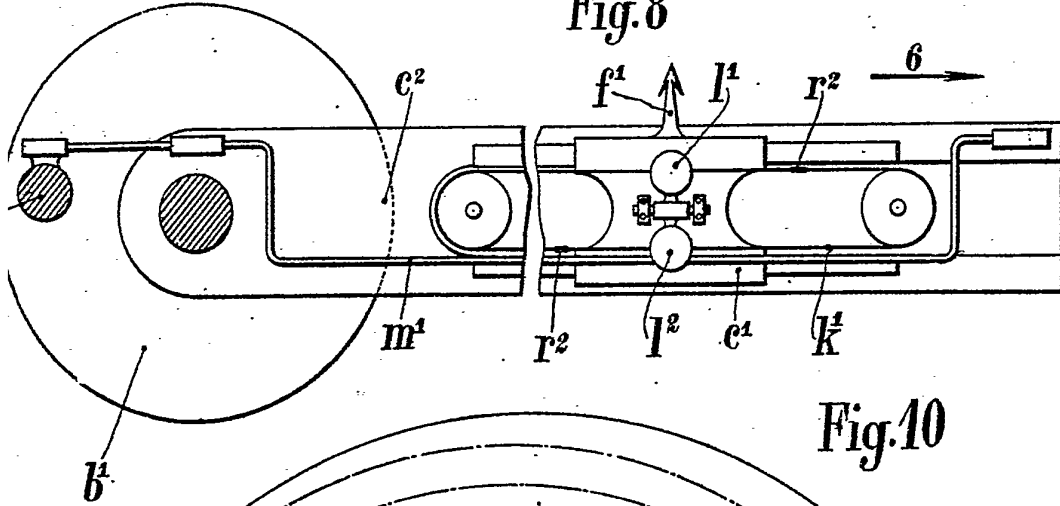
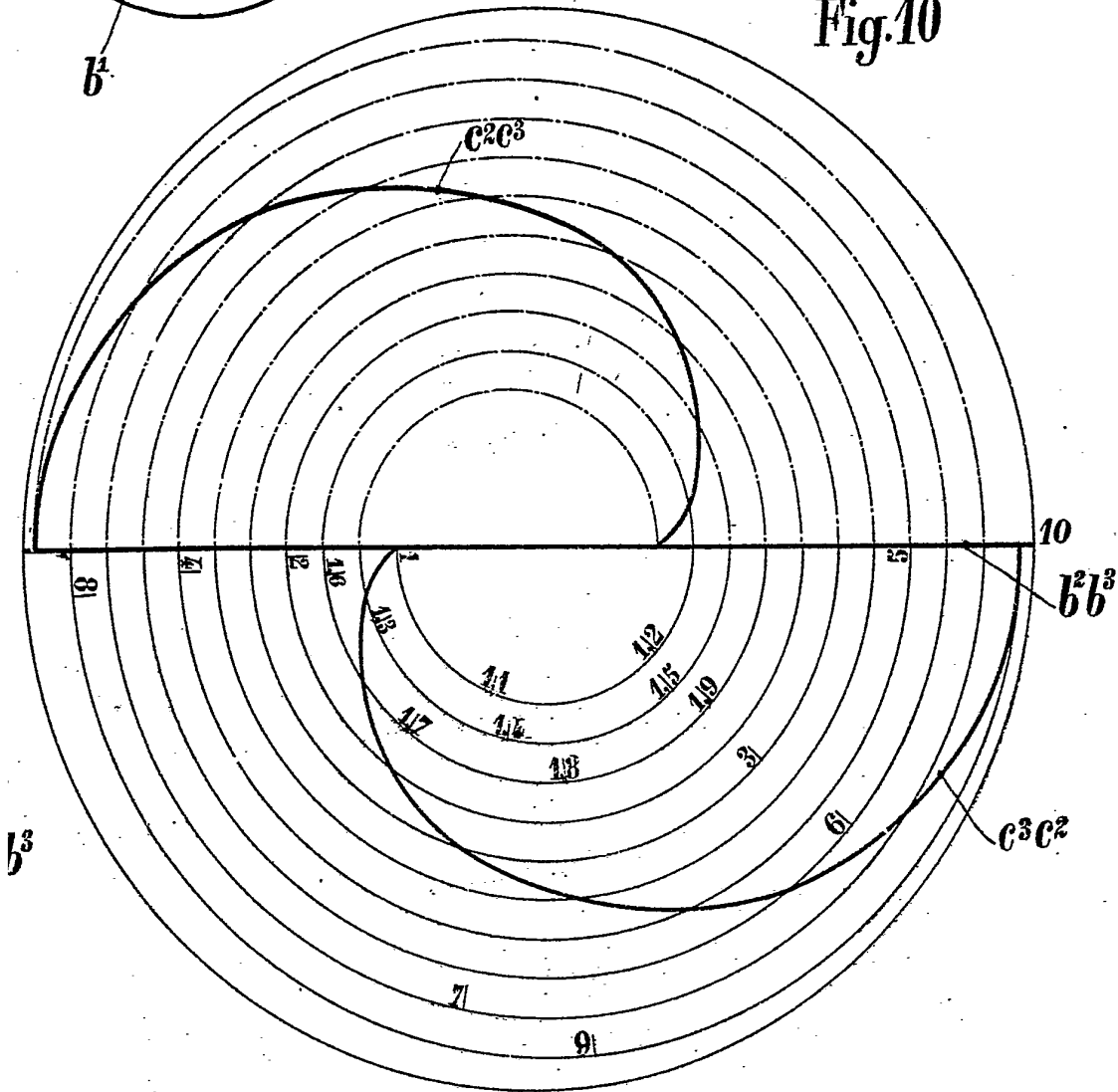

Fig. 10



[This Drawing is a reproduction of the Original on a reduced scale.]

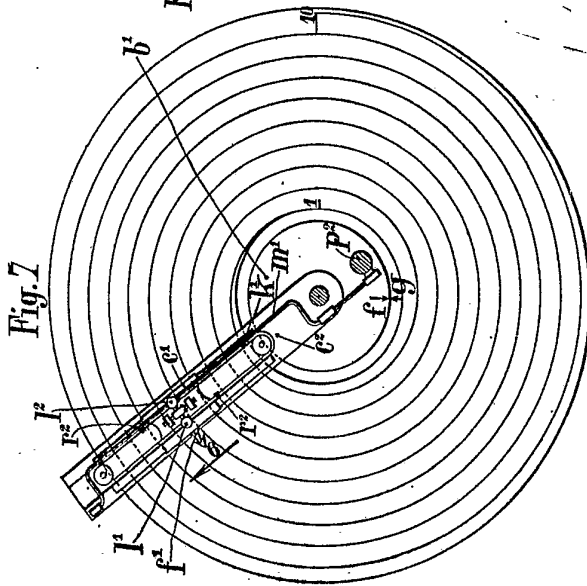

Fig. 8

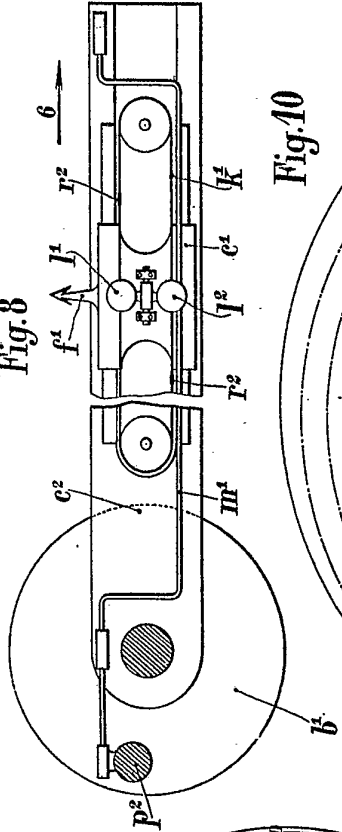

Fig. 10

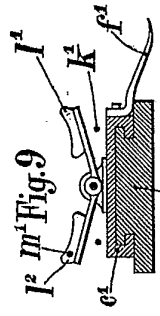
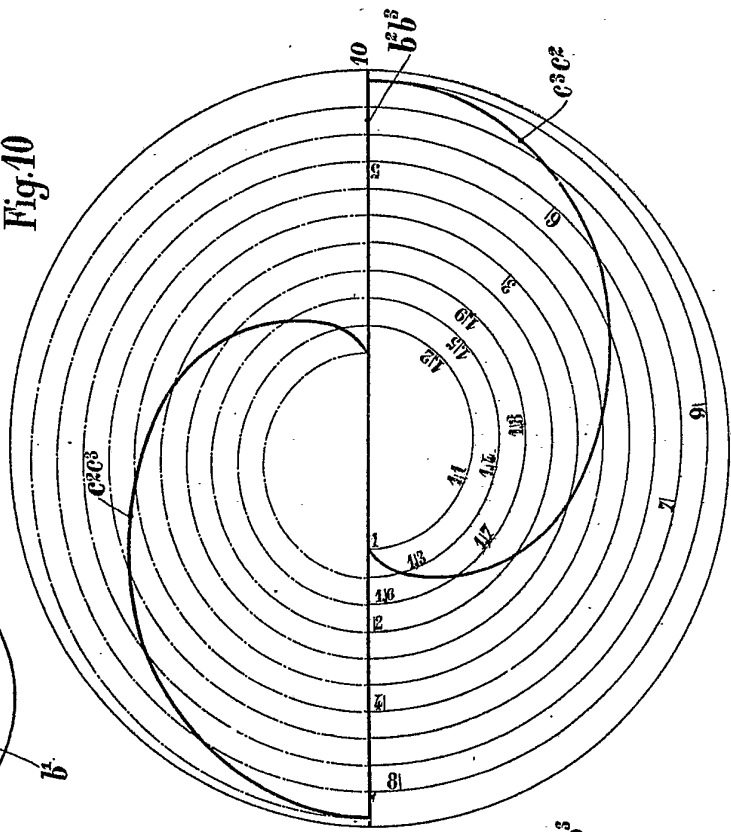

Fig. 9

Fig. 11

